



HD UNIT

INSTALLATION & SERVICE BOOKLET

3 - 7



 **OPREMA** d.d.



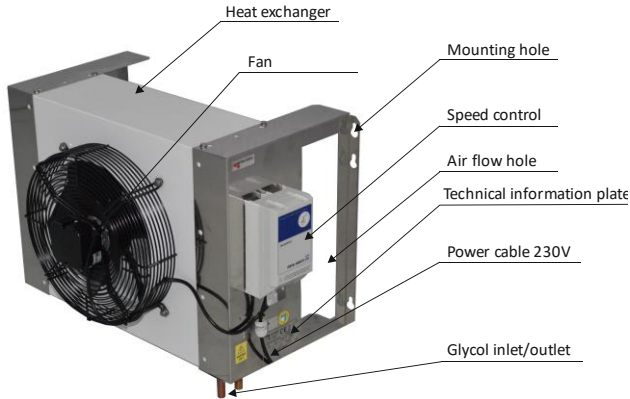

WARNING

During the installation the heat dump unit should be disconnected from the el. main until the final installation and putting into function is done.

USER INSTRUCTIONS

User instruction consists of installation and usage instructions. This instruction is integral part of every cooler unit, and it should always be with the cooler and also during every displacement or installation, so technical personnel could use it. Before installation and usage of cooler, you should carefully read this user instruction in which there are important information for correct and safe use. Unit weight is 18 kg.

NOTE: The unit should be installed and serviced by a suitably trained person.

1. Unpack the unit from its transportation packaging and visually inspect for signs of damage.
2. Site the heat dump in a convenient location, preferably in a non heat sensitive and shaded area on the outside of building. If it can not be installed outside, ensure that the area is free from other heat sources. The unit should be sited to allow free circulation of air. Height from the ground to base of unit should not exceed 9 metres. (30 feet)
3. Fix the unit to the wall.

HEAT DUMP PIPES

1. Heat dump pipes are 15 mm and must be run with a space between the flow and return.

2. Only approved glycol tubing can be used. PVC pipes must never be used – it is unsuitable for hot glycol.

DISMANTLING DECOMMISSIONING PROCEDURE

1. Plug out the unit from Electricity Supply.
2. Disconnect the recirculating coolant Inlet/Outlet pipes.

ADJUSTMENTS MAINTENANCE REQUIREMENTS

It is not recommended that the end user makes any adjustments or carries out any maintenance other than:

1. Check the mains lead and plug visually for condition.
2. Check the unit and its pipe work for evidence of leaks visually.

METHODS OF CLEANING

NOTE: Do not use a water or stream hose to clean the unit whilst still installed.

NOTE: It is important that all the vents and grills are kept clear (including condenser grills where applicable).

NOTE: Personal protective equipment should always be used.

Twice annually: by a competent service / maintenance engineer:

1. Isolate the unit from the base cooler Electricity supply
2. Remove any extraneous debris from the unit or its casing preferably using a vacuum cleaner or a brush.
3. Check unit for electrical safety.

Max. / min. ambient temperature (recommended)

Minimum: - 5 °C (nb 30% glycol/watermix)

Maximum: 32 °C

WARNING

*In accordance with current law regulation, installation and use of unit must be done by specialized and adequate trained **technical personnel**.*

SPEED CONTROL PKE-2.5V

UNIT OPERATION

To operate HD unit, power supply should be 230V, 50 Hz. Connecting cable (5m) is directly connected to control box. Electronic circuit installed into control box placed on HD unit has function that depending on temperature (according to temperature probe) of heat exchanger regulates fan speed. Important is that temperature probe is correctly installed on appropriate place, otherwise will operate incorrectly.

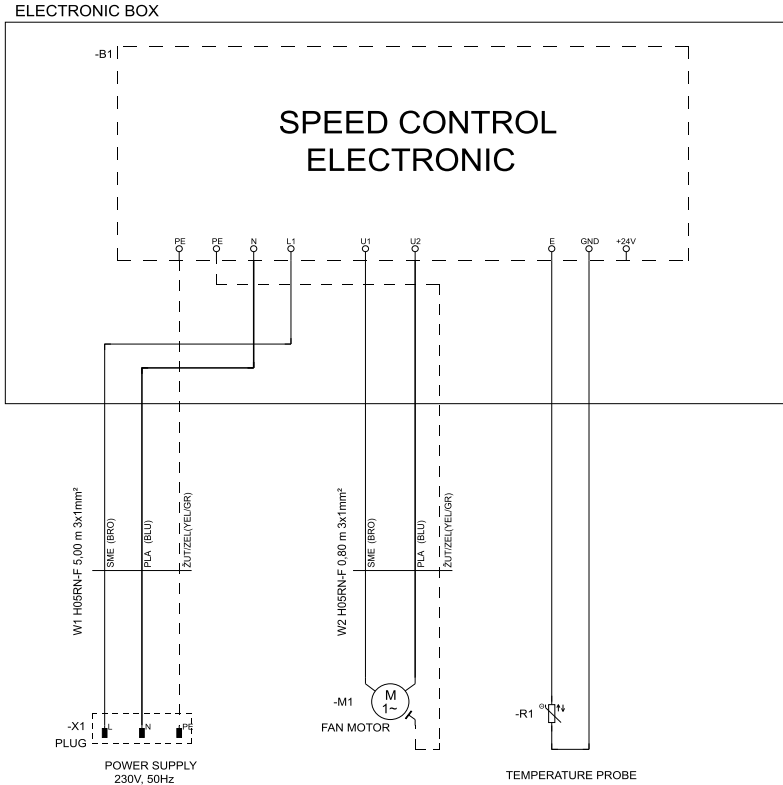

PROGRAMMING THE REQUIRED FUNCTION

Operation as controller = J1 to "Set" = down position:
(P-controller with increasing speed for increasing actual value)

Settings for "n-min", "P-band" and "Set" = REQUIRED value

For operation as a controller, the actual value measured by the sensor is compared with the nominal value that has been set. The output voltage and hence the rotational speed of the connected motor automatically change as a function of the parameter settings.

Sensor selection:

- Temperature sensor TF..(KTY10-6) = "J4" and "J5" up = "A" (factory settings) connection at terminals "E" and "GND"
- settings: set value "Set" 0-100% · 0-60°C, control range "Pband" 10-30% · 6-18 , "n-min" 0-100% (measuring range approx. 0 to 80 °C)

Oprema settings:

JUMPER

- J1 SET
- J4 A
- J5 A

POTENTIOMETERS

- n-min adjusted to 0% (minimum)
- Pband adjusted to 30% (maximum)
- Set adjusted to 50% (~30-35°C, middle position)

Technical data

- Line voltage 1-230V (-15% / +10%), 50/60 Hz
 - Rated current 2.5A (at line voltage 230 V)
 - Min. motor current 0.2 A
 - Stepless controlled output voltage approx. 25-100% (deactivation at approx. 25%, restart at approx. 35%)
 - Maximum line fuse 10 A
 - Sensor supply +24 V (+20% / -31%) I_{max}. 20mA
 - Max. heat dissipation approx. 10 W
 - Max. permissible ambient temperature 40°C
 - Permissible rel. humidity 85% no condensation
 - Interference emission EN 50081-1
 - Interference immunity EN 61000-6-2
 - Harmonics current EN 61000-3-2
 - Housing protection / weight
- | | | |
|----------|-------|---------|
| PKE2.5V | IP 54 | 0,50 kg |
| PKE2.5VE | IP 20 | 0,26 kg |

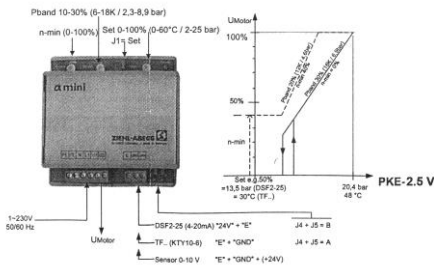

SAFETY INFORMATION

- Apart from the operating instructions and the obligatory regulations to be followed by users relating to accident prevention, the recognized technical regulations must also be observed (safety and branch-related work as per UVV, VBG, VDE, etc.).
- These devices are potentially dangerous if they are used incorrectly by untrained personnel or are not implemented according to their specified use.
- Work on electric components/modules may only be carried out by trained electricians in accordance with electro-technical regulations (e.g. EN60204, DIN VDE 0100/0113/0160). The contractor or owner must also ensure that the electric systems and equipment are operated and maintained in accordance with electro-technical regulations.
- It is forbidden to carry out work on electrically live parts. The enclosure rating of the device when open is IP00! It is possible to inadvertently touch components carrying hazardous voltages!
- During operation, the device must be closed or installed in a control cabinet.
- Fuses may only be replaced by new ones and must not be repaired or bypassed.
- Use only fuses mentioned in schematic diagram.
- The safe isolation from the supply must be checked using a two-gole voltage detector.
- Any faults detected in the electric system/modules/operating equipment must be corrected immediately. If these faults are not corrected, the device/system is potentially very dangerous. The device/system must therefore not be operated when it is faulty.

Transport and storage

- Always use the original packaging materials when transporting the controller.
- Avoid shocks and impacts to the device.
- Check the packaging and controller for damage.
- Store the controller in its original packaging in a dry and weather-proff room.
- The device must not be exposed to extreme heat and low temperatures

DISASSEMBLING INSTRUCTIONS

Disassembling procedure must be done in accordance with law regulations related to:

- Steel, plastic and other materials should be put aside by authorized person
- Insulation material must be removed by authorized companies and persons
- Symbol of crossed can means that product at the end of its life cycle must be put apart from other waste, related with decreasing use of dangerous substances in electrical and electronic devices, and also in accordance with adequate waste disposal. Individual collection and recycling of this equipment allow us to avoid negative effects on environment, and we can recycle and again use some of the parts. Unauthorized disposal of units by users can be penalized in accordance with current law regulations



